



Facade Test Laboratory P1

Measurement	Sound insulation, Normalized flanking level difference
Standard	DIN EN ISO 10848, DIN EN ISO 10140
Measuring objects	Facade elements, prototypes including installations, noise barriers (gabions etc.), exterior building elements

Technical data

Room volume	71 m ³ und 87 m ³
Entrance doors (H x W)	1,99 m x 0,86 m and 2,02 m x 0,95 m
External opening (H x W)	10,30 m x 3,53 m (max. 3,65 m)
Max. sound reduction (related to the max. size of test sample)	$R'_{\max,w} = 71$ dB

More information

- Delivery and direct installation of large test samples via Truck-mounted crane
- Access to the test facility at ground level and passable.
- Rolling gate to close the test opening (weather protection)
- Installation of large-size facade elements in front of the test opening (also horizontal) is possible.
- Glass installation accumulator vacuum for large-size glazing units with adequate lifting device at a forklift is available.
- Compressed air and electric power available

Horizontal section of the test facilities with high-quality sound insulating partition (dimensions in cm)

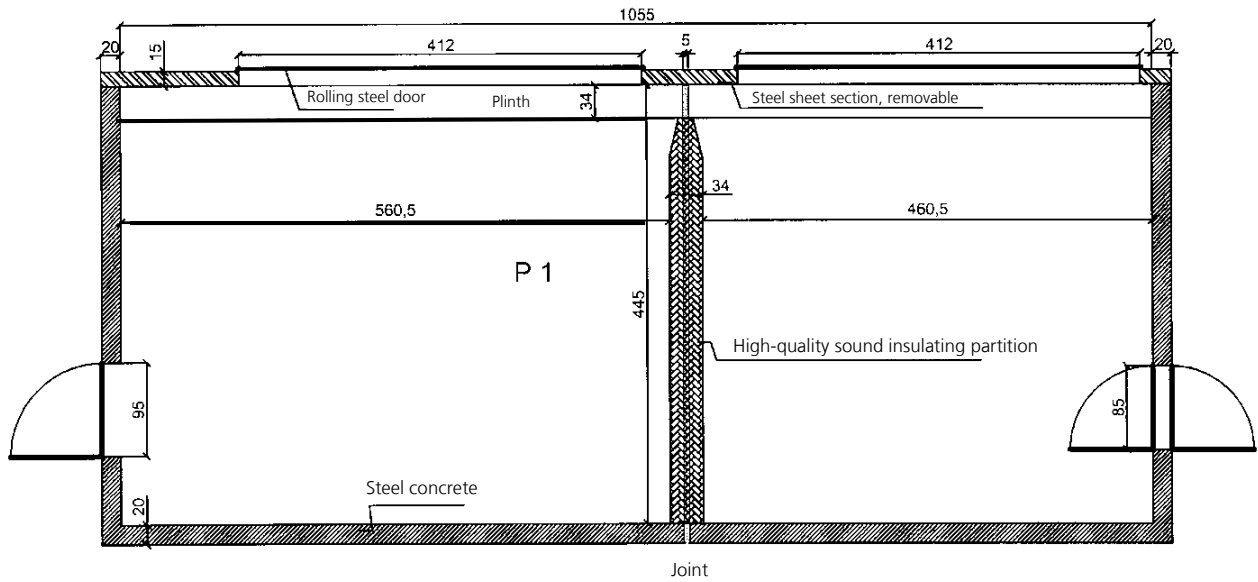

The test laboratory of the Fraunhofer IBP has been granted flexible accreditation according to DIN EN ISO/IEC 17025 by Deutsche Akkreditierungsstelle GmbH (DAkkS).